

Blinds Chalet

Constant Tension E-Z Lift Installation

Instructions

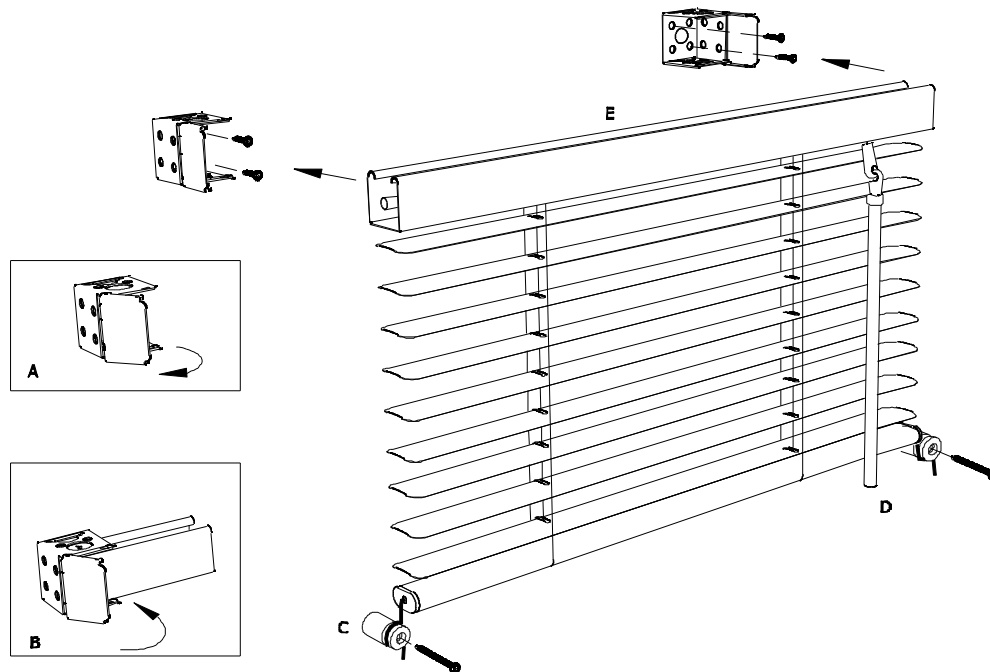

1. Open the box brackets (A) by carefully pinching the sides of the bracket and swinging the locking cover open.
2. **Wall Mount Installation:** Hold the blind level at the desired height and mark the window frame or wall lightly on each end at the bottom of the headrail. Now center the blind (using the marks as a guide) and mark the exact position of the ends of the headrail (F). Locate the brackets (A) $\frac{1}{4}$ " past the endmarks.
3. **Inside the Window Frame Installation:** Mount the brackets in the corner of the jambs, making sure the headrail (F) is level.
4. Having installed the left and right brackets, you are now ready to insert the headrail (E) into the bracket and snap the locking cover shut (B).
5. Mount Cord Retainer and Spacer (C) $\frac{1}{2}$ " directly below the bottom rail and secure to wall. If the tension is loose, you may either re-tie the knot or wrap cord around the cord retainer. **NOTE:** If the tension is too tight, the tilter mechanism which opens and closes the blind may not operate correctly; if so, the cording will need to be adjusted by loosening the cord and tying a new knot.
6. Secure wand (D) to tilter mechanism.